

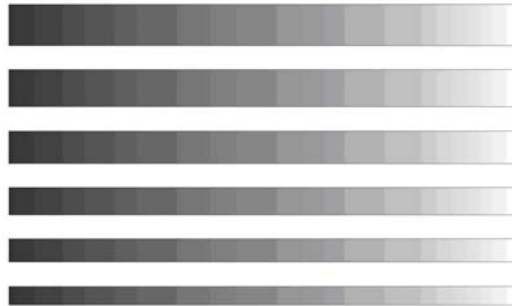

---

# RANGE HOOD OPERATING INSTRUCTIONS



Before using this range hood,  
please read these instructions  
completely.



**READ AND SAVE THIS INSTRUCTIONS**

**FOR DOMESTIC COOKING ONLY**

**Installer: Leave this manual with the homeowner.**

**Homeowner: Cleaning, Maintenance and Operating  
instructions on the coming pages.**

**RANGE HOOD ITEM NO.: K1012/K1012A**

**REFERRED MODEL NO.: 3503A/3503D**



**MOTOR WITH UL CERTIFICATE**

# READ AND SAVE THESE INSTRUCTIONS

**⚠ INTENDED FOR DOMESTIC COOKING ONLY ⚠**

## **⚠ ⚠ WARNING**

**TO REDUCE THE RISK OF FIRE, ELECTRIC SHOCK, OR INJURY TO PERSONS, OBSERVE THE FOLLOWING:**

1. Use this unit only in the manner intended by the manufacturer. If you have questions, contact the manufacturer at the address or telephone number listed in the warranty.
2. Before servicing or cleaning unit, switch power off at service panel and lock service panel to prevent power from being switched on accidentally. When the service disconnecting means cannot be locked, securely fasten a prominent warning device, such as a tag, to the service panel.
3. Installation work and electrical wiring must be done by a qualified person(s) in accordance with all applicable codes and standards, including fire-rated construction codes and standards.
4. Sufficient air is needed for proper combustion and exhausting of gases through the flue (chimney) of fuel burning equipment to prevent backdrafting. Follow the heating equipment manufacturer's guidelines and safety standards such as those published by the National Fire Protection Association (NFPA), and the American Society for Heating, Refrigeration and Air Conditioning Engineers (ASHRAE), and the local code authorities.
5. When cutting or drilling into wall or ceiling, do not damage electrical wiring and other hidden utilities.
6. Ducted fans must always be vented to the outdoors.
7. Do not use this unit with any separate solid-state speed control device.
8. To reduce the risk of fire, use only metal ductwork.
9. This unit must be grounded.

**TO REDUCE THE RISK OF A RANGE TOP GREASE FIRE:**

- A. Never leave surface units unattended at high settings. Boilovers cause smoking and greasy spillovers that may ignite. Heat oils slowly on low or medium settings.
- B. Always turn hood ON when cooking at high heat or when flambeing food (i.e. Crepes Suzette, Cherries Jubilee, Peppercorn Beef Flambe').
- C. Clean ventilating fans frequently. Grease should not be allowed to accumulate on fan or filter.
- D. Use proper pan size. Always use cookware appropriate for the size of the surface element.

## **⚠ ⚠ WARNING**

**TO REDUCE THE RISK OF INJURY TO PERSONS IN THE EVENT OF A RANGE TOP GREASE FIRE, OBSERVE THE FOLLOWING:\***

1. SMOTHER FLAMES with a close-fitting lid, cookie sheet, or metal tray, then turn off the burner. BE CAREFUL TO PREVENT BURNS. If the flames do not go out immediately, EVACUATE AND CALL THE FIRE DEPARTMENT.
2. NEVER PICK UP A FLAMING PAN - You may be burned.
3. DO NOT USE WATER, including wet dishcloths or towels - violent steam explosion will result.
4. Use an extinguisher ONLY if:
  - A. You know you have a Class ABC extinguisher and you already know how to operate it.
  - B. The fire is small and contained in the area where it started.
  - C. The fire department is being called.
  - D. You can fight the fire with your back to an exit.

\* Based on "Kitchen Fire Safety Tips" published by NFPA.

## CAUTION

---

1. To reduce risk of fire and to properly exhaust air, be sure to duct air outside. Do not vent exhaust air into spaces within walls or ceilings or into attics, crawl spaces, or garages.
2. Take care when using cleaning agents or detergents.
3. Avoid using food products that produce flames under the Range Hood.
4. For general ventilating use only. Do not use to exhaust hazardous or explosive materials and vapors.
5. To avoid motor bearing damage and noisy and/or unbalanced impellers, keep drywall spray, construction dust, etc. off power unit.
6. Your hood motor has a thermal overload which will automatically shut off the motor if it becomes overheated. The motor will restart when it cools down. If the motor continues to shut off and restart, have the hood serviced.
7. For best capture of cooking impurities, the bottom of the hood should be a minimum of 24" and a maximum of 33" above the cooking surface.
8. Two installers are recommended because of the large size and weight of this hood.
9. This product is equipped with a thermostat which may start blower automatically. To reduce the risk of injury and to prevent power from being switched on accidentally, switch power off at service panel and lock or tag service panel.
10. Use with approved cord-connection kit only.
11. Please read specification label on product for further information and requirements.

# PREPARE THE HOOD

Unpack hood and check contents.

You should receive:

1 - Hood

1 - Decorative Flue Assembly

1 - Parts Bag containing:

1 - Mounting Bracket

1 - Vent

1 - Duct fixing support

1 - Slidery duct fixing support

7 - Mounting Screws (4 x 50mm)

10 - Mounting Screws (4 x 8mm)

9 - Drywall Anchors (2 for  $\phi$  8 holes)

2 - Mounting Screws (4 x 35mm for  $\phi$  8 holes)

2 - Washer (for  $\phi$  8 holes)

1 - Aluminum Flex Duct

1 - Installation Instructions

1 - Warranty Card

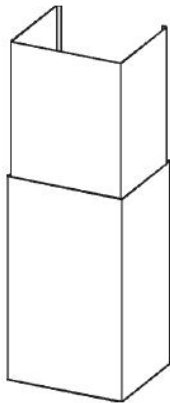

DECORATIVE  
FLUE

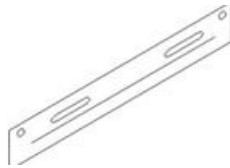

DUCT FIXING SUPPORT

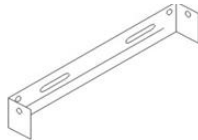

SLIDERY DUCT FIXING SUPPORT



VENT



MOUNTING  
SCREWS (4  
X 8MM)

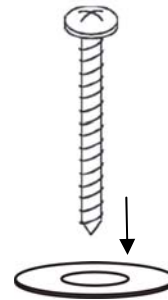

MOUNTING  
SCREWS (4  
X 35MM)

WASHER



DRYWALL  
ANCHORS



MOUNTING  
SCREWS (4 X  
50MM)



ALUMINUM FLEX  
DUCT

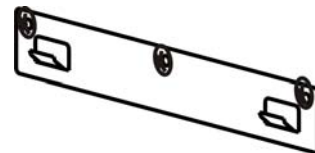

MOUNTING  
BRACKET

## **WARNING**

**Note:** This range hood must be properly grounded. The unit should be installed by a qualified electrician in accordance with all applicable national and local electrical codes.

The minimum hood distance above cooktop must not be less than 24". A maximum of 33" above cooktop is highly recommended for best capture of cooking impurities. Distances over 33" are at the installer and users discretion.

## **INSTALL THE DUCTWORK**

**NOTE:** To reduce the risk of fire, use only metal ductwork.

1. Decide where the ductwork will run between the hood and the outside.
2. A straight, short duct run will allow the hood to perform most efficiently.
3. Install the Aluminum Flex duct on the vent towards hood location.

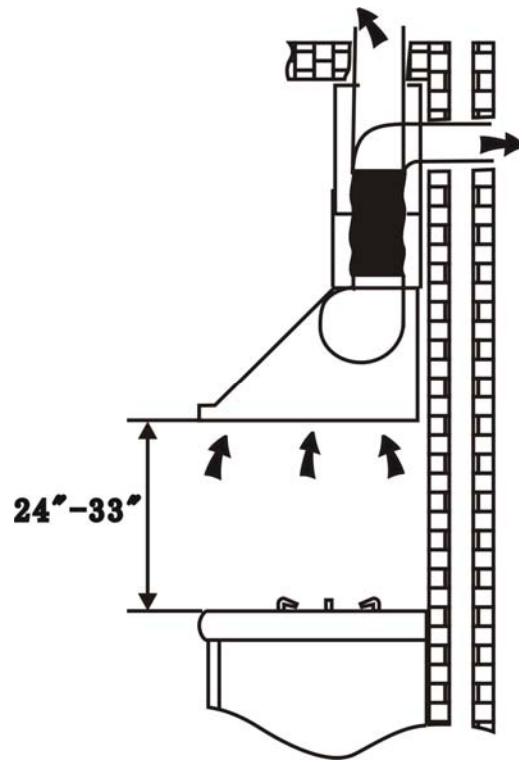

## **INSTALL MOUNTING BRACKETS**

1. After evaluating the height of the hood, place the hook center over installation location. Drill 3 holes of  $\varnothing 8\text{mm}$  on a suitable place to fix the mounting brackets.
2. Put the drywall anchors into the holes and fix the mounting screws (4x50mm) into the anchors, and install the hook on the wall as shown.

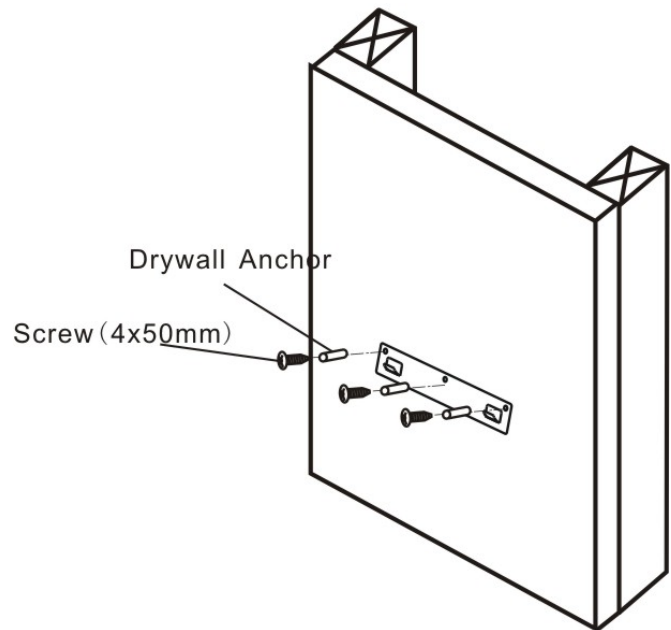

## **INSTALL SLIDERY DUCT FIXING SUPPORT**

1. Calculate the final height of the U-shaped section, drill 2 holes of  $\varnothing 8\text{mm}$  on a suitable place in line with the slidery duct fixing support.
2. Put the drywall anchors into the holes and fix the mounting screws (4x50mm) into the anchors, and install the hook on the wall as shown. (The rest two pares of 4x50mm screw and drywall anchors are for spare)

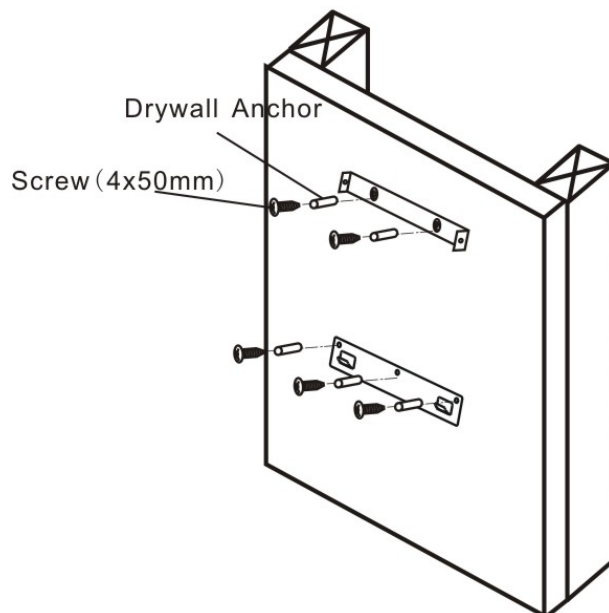

## **NONE-DUCTED RECIRCULATION FILTER INSTALLATION**

1. Purchase a non-ducted recirculation filter from your dealer.
2. Install the filter by rotating it onto the equipment which stands on two sides of the motor.

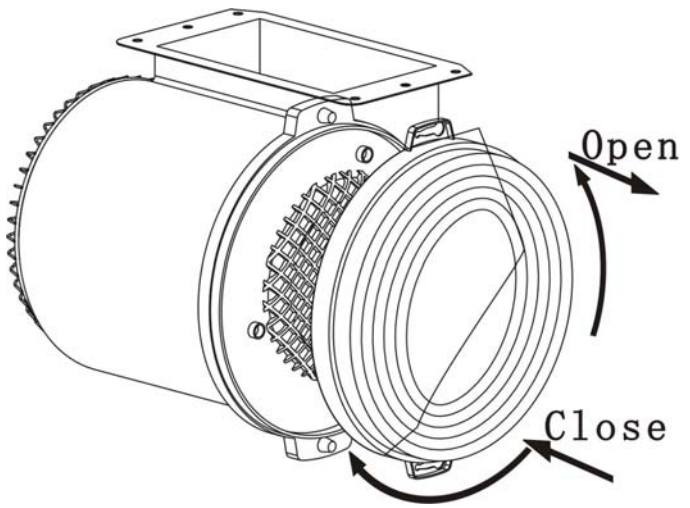

## **PREPARE THE HOOD**

**Note:** On stainless steel hoods, carefully remove the plastic protective film from all exterior surfaces of the hood and decorative flues, prior to final installation.

3. Pick out the hood from the carton.
4. Install the vent into the duct connector of the cooker hood.
5. Fix the extensive pipe onto the vent.

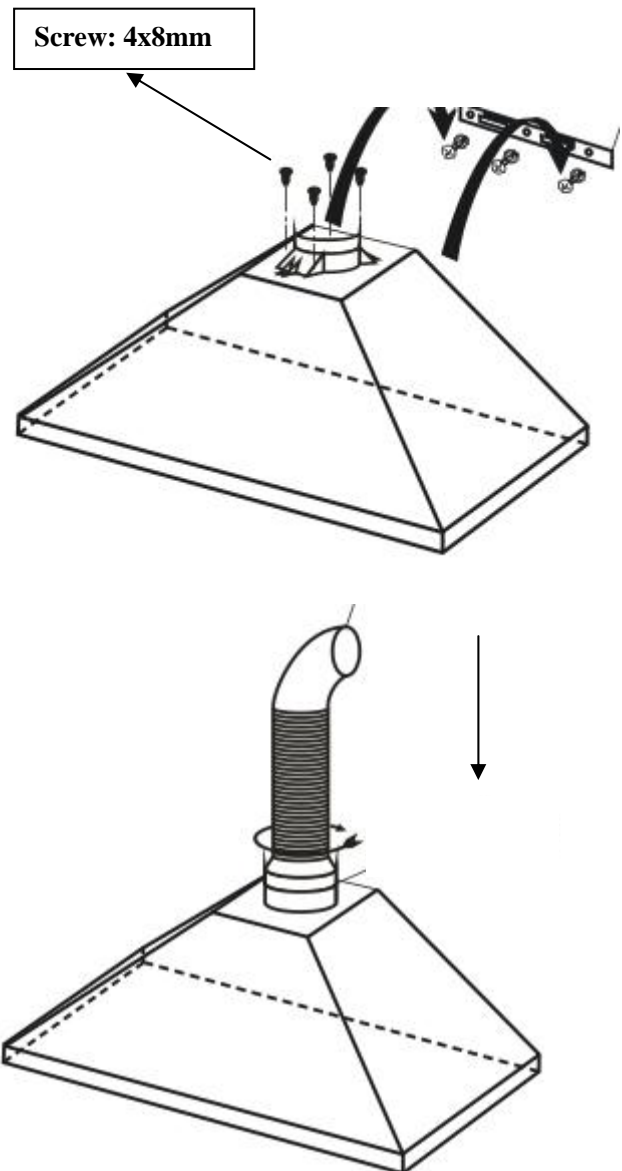

# INSTALL THE HOOD

**Note: at least two people will be required to mount the hood.**

1. Raise the hood into its mounting position.
2. Align the rectangular opening on the back of the hood with the wall-mounting bracket. Gently lower the hood until it securely engages the bracket.
3. Open the Al. filter and find the two  $\phi 8$  mm holes on the back of the hood. Level the hood with 2 mounting screws (4\*35mm) with washer. Use drywall anchors provided.

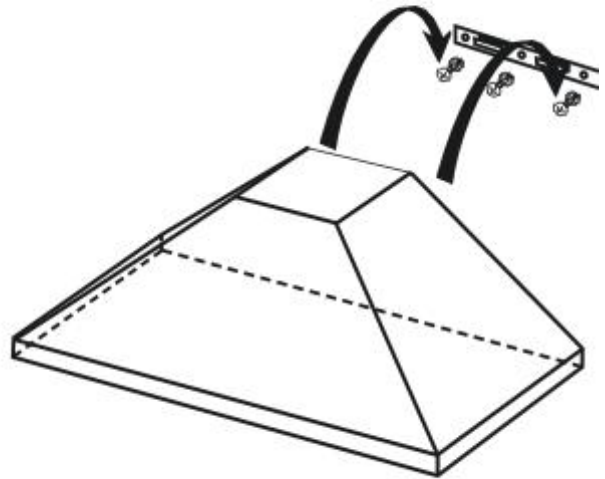

4. Measure the height of the glass to the sliding duct fixing support. Adjust the height of the chimney according to the height. Then use the duct fixing support with two screws (4x8mm) to fix the chimneys. Shown as in the pic.

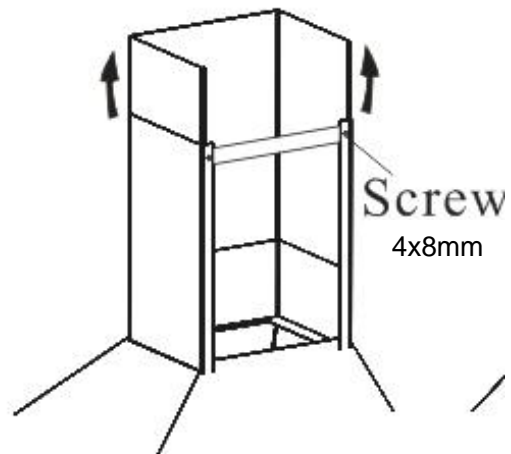

5. Put the chimney on the hood, use two screws (4x8mm) to fix the chimney to the sliding duct fixing support.

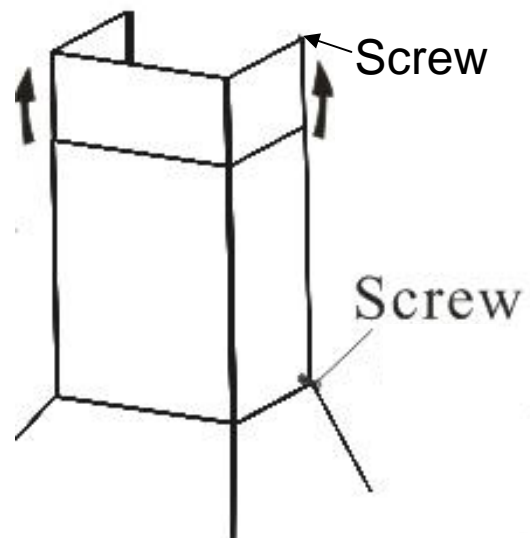

6. Use the other two screws (4x8mm) to fix the bottom of chimney.



## **MAINTENANCE**

Proper maintenance of the Range Hood will assure proper performance of the unit.

### ***Filters***

The filters must be cleaned approximately once every 30 hours of operation (when the central segment on the display goes on or starts blinking).

Use a warm detergent solution. Grease filters are dishwasher safe.

Remove filter by pushing filter towards the back of hood and rotating filter downward.

### ***Ductfree(Carbon) Filters***

The ductfree filters should be changed every 6 months. Rotate the filters to remove and replace.

### ***Hood Cleaning***

Stainless steel is one of the easiest materials to keep clean. Occasional care will help preserve its fine appearance. Cleaning tips:

- Hot water with soap or detergent is all that is usually needed.
- Follow all cleaning by rinsing with clear water. Wipe dry with a clean, soft cloth to avoid water marks.
- For discolorations or deposits that persist, use a non-scratching household cleanser or stainless steel polishing powder with a little water and a soft cloth.
- For stubborn cases, use a plastic scouring pad or soft bristle brush together with cleanser and water. Rub lightly in direction of polishing lines or "grain" of the stainless finish. Avoid using too much pressure which may mar the surface.
- DO NOT allow deposits to remain for long periods of time.
- DO NOT use ordinary steel wool or steel brushes. Small bits of steel may adhere to the surface causing rust.
- DO NOT allow salt solutions, disinfectants, bleaches, or cleaning compounds to remain in contact with stainless steel for extended periods. Many of these compounds contain chemicals which may be harmful. Rinse with water after exposure and wipe dry with a clean cloth.

Painted surfaces should be cleaned with warm water and mild detergent only.

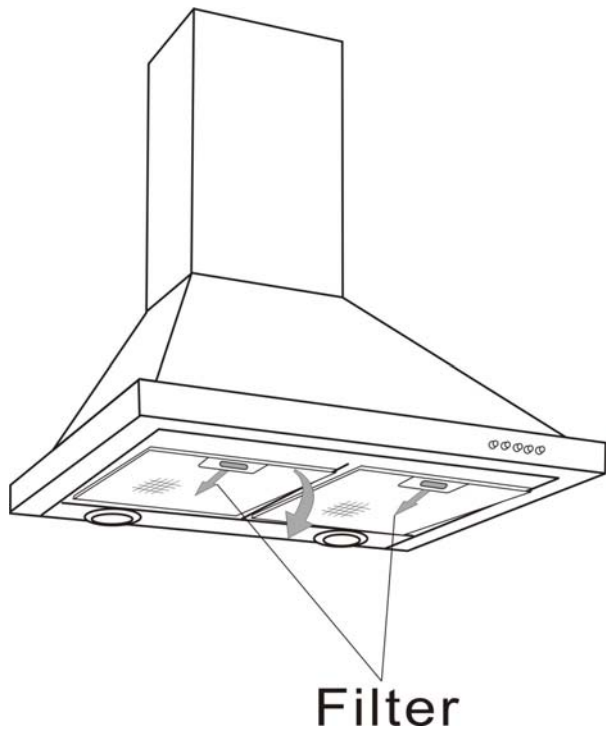

# OPERATION

## Controls

Always turn the hood ON before cooking in order to establish an air flow in the kitchen. After turning off the range, let the hood run for a few minutes to clear the air.

### ● Electronic Button

1. Turn on the power; the buzzer will buzz five times. The sound shows that the appliance is powered.
2. Push the low button, the indicating light 1 on, the buzzer will buzz once, and the motor runs at low speed. Push it again and the motor will stop.
3. Push the middle button, the indicating light 2 on, the buzzer will buzz once, and the motor runs at mid speed. Push it again and the motor will stop.
4. Push the high button, the indicating light 3 on, the buzzer will buzz once, and motor runs on high speed. Push it again and the motor will stop.
5. Push the light button; the indicating light 4 on, and the two lighting lamps will come on. Push it again and the lamps will turn off, with every push the buzzer will buzz one time.

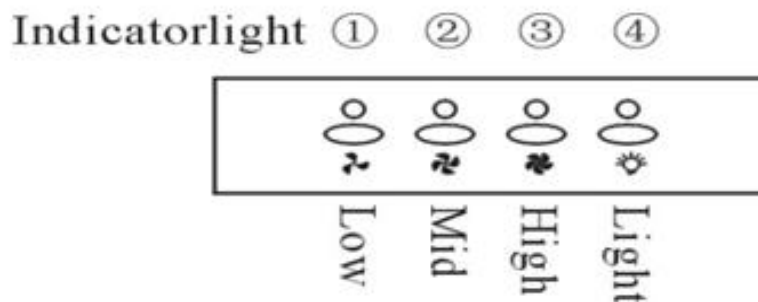

### ● Blue ring button

1. Turn on the power; the buzzer will buzz five times. The sound shows that the appliance is powered.
2. Push the low button, the indicating light on, the buzzer will buzz once, and the motor runs at low speed. Push it again and the motor will stop.
3. Push the middle button, the indicating light on, the buzzer will buzz once, and the motor runs at mid speed. Push it again and the motor will stop.
4. Push the high button, the indicating light on, the buzzer will buzz once, and motor runs on high speed. Push it again and the motor will stop.
5. Push the light button; the indicating light on, and the two lighting lamps will come on. Push it again and the lamps will turn off, with every push the buzzer will buzz one time.

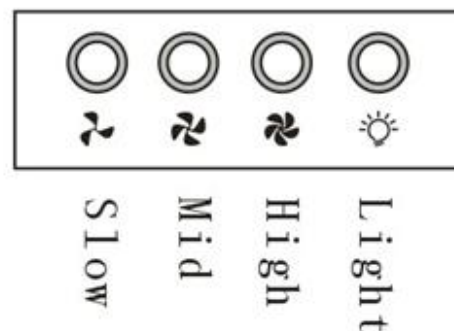

## HALOGEN BULBS

**ALWAYS SWITCH OFF THE ELECTRICITY SUPPLY BEFORE CARRYING OUT ANY OPERATIONS ON THE APPLIANCE.**

To change bulbs:

1. Rotate the cover in anticlockwise, as shown.  
CAUTION: BULB MAY BE HOT, PLEASE ROTATE WHEN THE BULB IS COOL!
2. Replace with a Type JC, 12Volt, 20Watt Max, G-4 Base bulb. Do not touch replacement bulb with bare hands! If the bulb is touched with the bare hand, it should be cleaned with a lint-free cloth moistened with methylated spirit.



## LED LIGHTS

**ALWAYS SWITCH OFF THE ELECTRICITY SUPPLY BEFORE CARRYING OUT ANY OPERATIONS ON THE APPLIANCE.**

To change the light:

1. Open the filter and find the spring of the light, push the spring and the light will slip out. Change the light as with same kind of 4Volt,3 Watt LED light. CAUTION: LIGHT MAY BE HOT, PLEASE ROTATE WHEN THE LIGHT IS COOL!

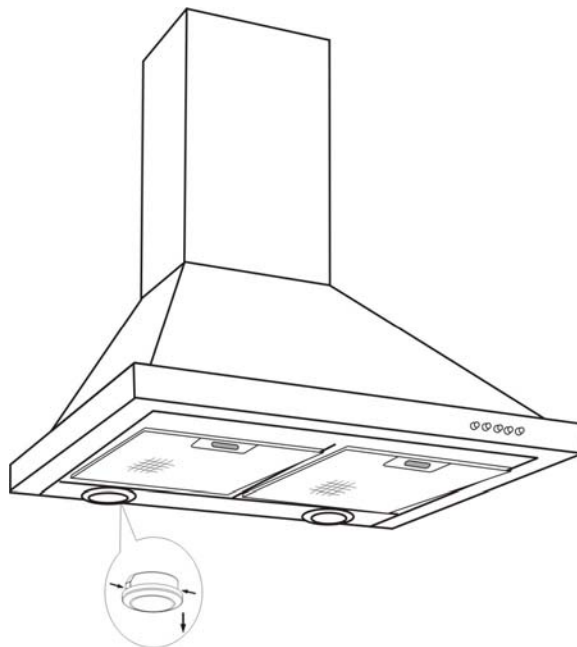

## WARRANTY

We will warrant this product free from defects in material and quality for one year and motor for 5 years. If any problems occur from correct usage, please contact the service department for under warranty service.

This warranty does not cover the following:

The filter mesh and bulb.

Commercial use.

Amendment of the date of manufacture on the rating plate.

Damaged caused to the body by usage of detergent sprayer.

Pollution made to the led parts, glass parts and S/S parts.

Incorrect installation, misuse, abuse or neglect.

Incorrectly fitted to insufficient or unsuitable power.

Taken apart or serviced by unauthorized service engineers or replaced with other manufacture's components.

For commercial use the maintenance and free service should be discussed with our authorized agent.

Beyond the 12 month limited warranty period, the purchaser should pay for charge of components and call out.

In the event of a service call, please provide the warranty card and receipt of date of purchase.

**K-Star International Group Inc.**  
**K-Star Electronic Appliance Inc.**

Toll Free:(800) 893-2168

Email:info@kstarus.com

<http://www.kstarus.com>